

USER  
GUIDE

**IMPACT 21**

*Not actual front page*

801.060C  
USG/021/AE-C  
14.06.95



# USER GUIDE

**IMPACT 21**



## TABLE OF CONTENTS

1 INTRODUCTION.....	5
2 MAIN FEATURES .....	5
3 SUPPLIED MATERIAL.....	6
4 OPTIONAL MATERIAL .....	6
5 SETTING UP THE LCD PANEL .....	7
6 USING THE LCD PANEL .....	8
6.1 REMOTE CONTROL.....	8
6.2 FRONT PANEL.....	10
6.3 CONNECTORS .....	10
7 FEATURES.....	11
8 PRACTICAL HINTS AND TIPS.....	15
9 MAINTENANCE .....	16
10 SERVICE .....	16
11 TECHNICAL DATA.....	17
12 CONNECTORS.....	19
13 FCC STATEMENT .....	20
14 ENVIRONMENTAL STATEMENT.....	21
15 SERVICE INFORMATION .....	22
16 CONNECTION LAYOUT .....	23

(Foldout Page)

This publication is printed on recycled paper.

The information contained in this user guide is preliminary, and the products described herein are subject to change without prior notice.

## 1 INTRODUCTION

The LCD panel is a state of the art projection device that can be connected to several sources, like the popular IBM, Apple and NEC computers, in addition to NTSC, PAL or SECAM video (through an external adapter).

The ability to display a multitude of true colors simultaneously, in real time, makes it the ideal choice for presenting computer generated text and graphics, television and video.

Applications include presentations, software training, educational use, advertising, information boards and other situations where a small or large audience shares information.

## 2 MAIN FEATURES

- **2.1 Million colors**
- **User settings memorized**
- **Individual settings for all sources**
- **Video through external adapter**
- **Correct VGA text mode**
- **Compatible with all popular computers**
- **Cable adapters for different computers**
- **BatMouse™, infrared remote mouse**
- **Housing footprint fits OHP glass exactly**
- **Low weight**
- **Intelligent fan cooling**
- **No false light**
- **4 meters Y-cable**

### 3 SUPPLIED MATERIAL

A complete set includes the following components :

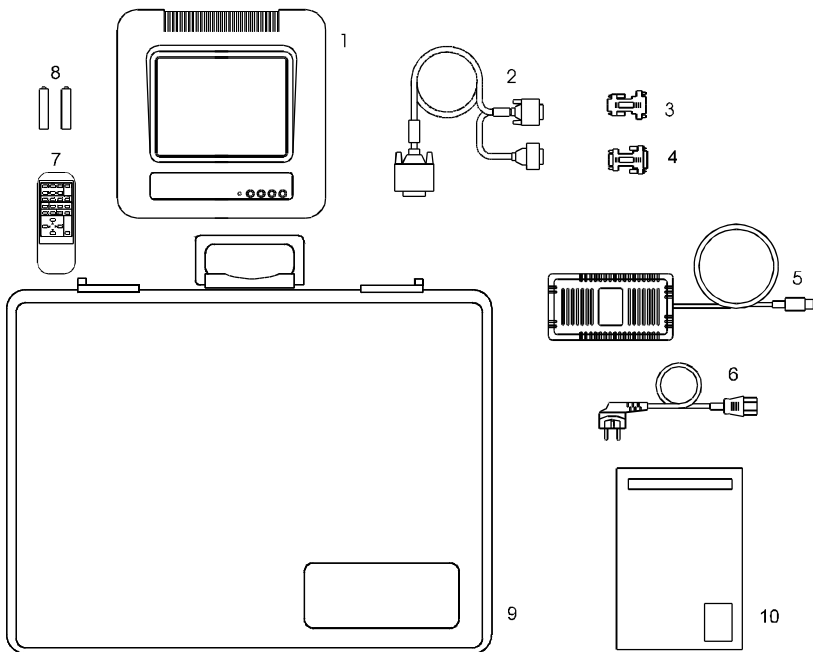

- |                             |                            |
|-----------------------------|----------------------------|
| 1. LCD Panel                | 6. Power Cable             |
| 2. VGA-Cable                | 7. BatMouse Remote Control |
| 3. Cable-Adapt. MACII mon   | 8. Batteries               |
| 4. Cable-Adapt. MACII comp. | 9. Attachè Case            |
| 5. Power -5, 12, 5 V        | 10. User Guide             |

### 4 OPTIONAL MATERIAL

Optional cables and adapters are available for special computer sources.

An external video adapter is available that is compatible with NTSC, PAL and SECAM.

## 5 SETTING UP THE LCD PANEL

Switch off all equipment before connecting the components. Be aware of static electricity that may build up, especially in the dry season and when operating on synthetic carpets. Discharge any static electricity by touching a metallic surface before you start.

Place the LCD panel on top of a transmissive overhead projector (OHP). Select a high intensity type projector, for instance 400W halogen or metal-halide. Best results are obtained in a dimmed room with no direct sunlight shining in.

Connect the cables and power supply as described in the rear foldout page (see *Connection Layout*). Cable adapters are not used with VGA, only with MACII and NEC9801.

Connect cable (1) between the LCD panel and the computer. Use the Y-split on the computer end to connect the monitor.

If you have a Macintosh, EGA, CGA or NEC computer, insert applicable adapters (2) and (3) as described in the table below.

Connect the power supply to the LCD panel (4).

<b>COMPUTER</b>	<b>CABLE</b>	<b>ADAPTER</b>
VGA	Analog	None
EGA/CGA	Digital (option)	None
MACII c../v../LC/ Quadra/Powerbook/ Duo	Analog	MACII (640x480)
NEC 9801	Analog	NEC 9801(option)

## 6 USING THE LCD PANEL

The LCD panel has a set of connectors and controls that you need to know in order to operate the device correctly.

### 6.1 REMOTE CONTROL

The infrared BatMouse remote control (RC) is the main user interface to the device. The RC is used to set the device correctly (to get the best possible viewing conditions).

The figure shows the different keys of the BatMouse.

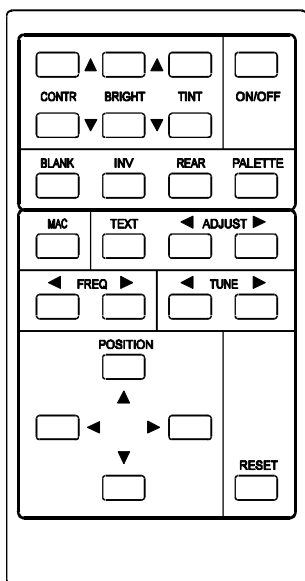

Set-up should be done once with the application(s) you are running most frequently. Allow some minutes for the equipment to warm up before adjusting. Most settings will automatically be memorized individually for each source for future use.

The 'MEM' column indicates whether the setting is memorized for each source. For a detailed overview, see the *Features* section.

#### PRESENTATION CONTROLS

<b>CONTROL</b>	<b>FUNCTION</b>	<b>MEM</b>
CONTR	Contrast (ratio between light and dark colors)	YES
BRIGHT	Brightness (whiteness)	YES
TINT	Color balance	NO
BLANK	Blanks the screen	NO
INV	Inverts the black and white contents of the image	NO
REAR	Mirrors the image for rear projection	NO
PALETTE	Selects color resolution of 512 / 4K / 2.1M	YES
ON/OFF	Turns the panel on/off	-

#### SET-UP CONTROLS

<b>CONTROL</b>	<b>FUNCTION</b>	<b>MEM</b>
MAC	Toggles between MACII (default)/MACII LC	NO
TEXT	Selects VGA text mode (default)	YES
ADJUST	For correct compression of VGA text	YES
FREQ	Adjusts the video frequency	YES
TUNE	Adjusts the stability of the image	YES
POSITION	Controls the image position	YES
RESET	Defaults to standard settings	-

## 6.2 FRONT PANEL

The keyboard consists of a subset of the remote control keys.



<b>CONTROL</b>	<b>FUNCTION</b>
TUNE	Adjusts the stability of the image
BRIGHT	Adjusts the brightness (whiteness) of the image
RESET	Defaults to factory settings

## 6.3 CONNECTORS

All connectors are positioned on the right hand side of the LCD panel. See the technical data section for pinouts of the various connectors.

Do not connect any other devices with similar plugs to the connectors of the LCD panels, as this voids any warranty and may cause permanent damage to the device.



<b>CONNECTOR</b>	<b>FUNCTION</b>
POWER	Low voltage power supply
AUX	Auxiliary connector for future use

## 7 FEATURES

The LCD panel has a variety of different features implemented. This chapter explains each feature in detail.

### **AUTOMATIC FAN CONTROL**

The fan operation is controlled by the overhead projector light (OHP). This safety feature ensures that the fan is always operating as long as the OHP is turned on. When the OHP is turned off, the fan automatically stops to minimize noise. The power supply must be attached to the panel for the fan to work properly.

### **SET-UP MEMORY**

The user controlled set-up that usually is done when the panel is adapted to a new computer, is automatically memorized for future use. The set-up information is stored in a non-volatile memory.

The memory can store 40 different sources/modes. Approximately 10 sources are predefined, while the remaining 30 are available for customer set-up of sources.

The custom sources will be stored in new locations if their sync pattern is different from those predefined. If the set-up is only a variety of a standard source (same sync pattern) the old setting will be changed and stored in the existing location.

Most settings are stored individually for each source, including contrast, brightness, tune etc. See the remote control table above.

### **CONTRAST**

The contrast of an image is defined as the relation between dark and light colors. An image of high contrast is often regarded as 'hard', as compared to the 'soft' feeling of a low contrast image. Low contrast is recommended for long term viewing, while high contrast is used to enhance details. Use the CONTR keys on the remote control (RC) to adjust the contrast. Also see *Brightness*. The contrast setting is stored individually for each source.

### **BRIGHTNESS**

The brightness is the amount of white in an image. The brightness is adjusted to the ambient lighting conditions. Usually, a bright, low contrast image is preferred. Use the BRIGHT keys to adjust brightness. See also *Contrast*. The brightness setting is stored individually for each source.

**TINT**

The tinting refers to the color balance of an image. You may actively want to make an image warmer (more reddish) or colder (more bluish), or the colors of the graphic interface in your computer could be unbalanced and in need of adjustment. Use the TINT controls on the RC to adjust.

**BLANK**

Use the BLANK key on the RC, if you temporarily want to suspend the display of images. The BLANK key is a toggle function, and the screen goes white when activated.

**INVERSE**

This feature inverts the black-and-white contents of an image, retaining all other colors unchanged. This feature is also called 'night vision', because a black or dark grey color is turned light. The inverse function is most valuable in text applications, and rarely used with graphics.

**REAR**

The panel can be set to project a mirrored image for rear projection. Rear projection is used when only the actual image is displayed, without showing the projection equipment. A special transmissive screen is needed. A typical application is in exhibitions. REAR is a toggle function on the RC.

**PALETTE**

Usually, the palette is set to display the maximum number of colors available, regardless of application. Some uses may be better off with a reduced set of colors available. By pressing the PALETTE switch on the RC, the color palette is cycled between 512, 4096 and 2.1 million colors. The palette setting is retained individually for each source.

**ON/OFF**

This switch controls the operation of the panel. When switched on, all functions are active. When switched off, only the automatic fan control is operating. The ON/OFF switch is a toggle key.

**MAC**

The MACII series of computers are equipped with slightly different graphic interfaces that need manual setup on the RC to work correctly. Default is the MACII standard interface of 640x480 resolution. Pressing the MAC key toggles between the MACII LC 640x480 mode and the standard 640x480 mode. An erroneous mode will typically be seen as an image too wide or too narrow, as well as vertical unstable lines.

**TEXT**

The TEXT key is used to toggle between the MCGA graphics mode and the text mode, as this is not automatically detected. This feature is very useful, as it enables a correctly set text image without any loss of information. When the VGA text format of 720x400 was defined, it was made to look like the MCGA mode graphic sync pattern of VGA. (This means that on most panels, text is displayed as an underscanned, unstable image).

**ADJUST**

When viewing a text image, first tune the image (see TUNE) for a stable view. If you are not able to tune a stable text image, you are probably in MCGA mode. If necessary press TEXT to toggle, then retune. Then press the ADJUST keys until correctly shaped characters appear. Once this procedure is performed, it will be retained for future use. This setting will not affect any graphic mode settings.

**FREQUENCY**

This setting is usually not changed by the user. It is however provided in case of adaptation to special graphic cards that are close to one of those in the compatibility list. Generally, a bad frequency setting can be observed as an image too wide or too narrow, combined with vertical, unstable stripes. Press the FREQ keys (up or down) to correct the image. The setting will be retained individually for each source.

**TUNE**

This feature enables a stable image. An untuned image can be seen as sideways instability or 'swimming'. Press the TUNE buttons until a stable image is achieved. The setting is retained individually for each source.

**POSITION**

Due to minor variations in graphic cards, the horizontal and vertical position may need adjustment. Use the four arrow keys of POSITION for a correct set-up. The position is then memorized automatically for each source.

**RESET**

This feature enables standard settings of most controls (see the 'MEM' column in the remote control description, where YES also indicates a standard setting).

## 8 PRACTICAL HINTS AND TIPS

This is a list of what to do when things go wrong. Check the symptoms carefully if you experience any problem. The cure may be at your hands!

### **The LCD image is completely white.**

- Check if the cables are connected and that power is on.
- Check the ON/OFF switch.
- Check the BLANK switch.

### **The LCD image is too dark or too light.**

- Check the CONTRAST and BRIGHTNESS settings.

### **The LCD image projects wrong colors**

- Check the TINT setting.

### **Some colors are unstable or flickering**

- Try to adjust the CONTRAST, BRIGHTNESS or possibly TUNE.

### **The whole LCD image appears unstable or misplaced**

- Try to manually adjust the TUNE or POSITION.
- Alternatively, you are most probably connected to an incompatible computer or video card. See the features section for frequency adjustment and positioning.

### **The cooling fan is not working**

- The fan operation is controlled by the overhead projector light. Is the OHP turned on ?
- Check that the power supply is attached.

### **The remote control is not working**

- Check if the batteries need replacement.
- Be sure to point at the projection screen when operating.
- You may be too far away from the panel (max. distance 6 m)

## 9 MAINTENANCE

From time to time, the housing and protection glasses may be cleaned with a dampened, non abrasive cloth, possibly using a mild detergent to remove spots.

The upper protection glass is not removable, as it only needs cleaning from the outside (the inside is sealed to the LCD module).

The lower protection glass can be removed for cleaning. Place the unit upside-down on a soft cloth to avoid scratches. Using two fingers, press the protection glass out of the guide rail and slide out. Be careful not to touch or to drop any objects inside the housing. Replace the glass after cleaning.

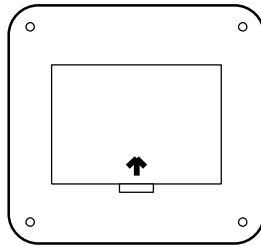

## 10 SERVICE

This product contains no user serviceable parts. Attempts to modify mechanics or electronics inside the housing will violate any warranties, and may be hazardous.

If for any reason the product fails to work properly, first check the previous chapter on hints and tips. If things still do not work, please contact your dealer for technical support. Prepare a list of the symptoms you observe to make the diagnosing easier for your dealer. Remember to include all cables and power supply when returning the goods.

If the problem cannot be solved by the dealer, please see the *Service Information* section.

## 11 TECHNICAL DATA

The technical data may change without prior notice in order to improve the product performance.

The apparatus is designed for indoor use and should not be operated outside the general environmental limits, as this may lead to permanent damage and violation of any warranties.

### GENERAL ENVIRONMENTAL LIMITS

STORAGE TEMPERATURE	-20 ~ 60 C (-4 ~ 140 F)
STORAGE HUMIDITY	10 ~ 90 percent relative humidity, non condensing
OPERATING TEMPERATURE	10 ~ 40 C (50 to 104 F)
OPERATING HUMIDITY	20 ~ 80 percent relative humidity

Allow for a slow acclimatization, after storing at extreme temperatures and humidities, to avoid condensation. Should condensation appear, operate for some time on an OHP, as the heat generated will evaporize the water.

### DISPLAY UNIT

Full color (RGB) unit connecting directly to external video sources.

SIZE	310x310x40 mm (WDH)
WEIGHT	2200 grams
POWER	-5, -12, 5 V (Universal)
LCD CELL	Active matrix TFT stripe configuration
COLOR RESOLUTION	2.1 Million
RESPONSE TIME	40 ms
CONTRAST RATIO	100:1
PIXEL RESOLUTION	640x480x3 (RGB)
SCREEN DIAGONAL	8.4 "
VIDEO FREQUENCY	25 ~ 35 MHz
HORIZONTAL SYNC	15 ~ 35 kHz
VERTICAL SYNC	50 ~ 80 Hz
FRAME REFRESH	Non-interlace
APPROVALS	FCC, Class A, Subpart J, Part 15

**POWER SUPPLY**

Primary switched universal type AC to DC converter.

INPUT VOLTAGE	100 to 250 VAC
OUTPUT VOLTAGES	+5VDC, +12VDC, -5VDC
CONNECTOR	5 pin DIN male
APPROVALS	TÜV, UL, CSA

**REMOTE CONTROL**

Infrared wireless remote control.

BATTERIES	2 pcs LR03 1.5V penlight
KEYS	24
RANGE	7 m

**COMPATIBILITY**

The unit is predefined for the following interfaces. In addition, the user can configure the panel for other interfaces with a total maximum of 40 definitions altogether (predefined and user defined).

<b>MODE</b>	<b>RESOLUTION</b>	<b>CABLE</b>	<b>CABLE ADAPTER</b>
VGA	640x480 640x400 640x350 720x400	Analog cable	None
SVGA	800x600 (compressed)	Analog cable	None
EGA	640x200 640x350	Digital cable	None
CGA	640x200	Digital cable	None
MACII	640x480	Analog cable	MACII
NEC 9801	640x400	Analog cable	NEC 9801

## 12 CONNECTORS

The pinouts of all external connectors are described.

### POWER

This connector feeds regulated DC power to the panel.



### COMPUTER

This connector relays all sync and data signals from the computer to the panel and back again to the CRT monitor.



1 ANALOG R IN	10 ANALOG R GND IN	19 HSYNC IN
2 ANALOG G IN	11 ANALOG G GND IN	20 C/VSYNC IN
3 ANALOG B IN	12 ANALOG B GND IN	21 DIGITAL GND
4 DIGITAL R IN	13 DIGITAL SR IN	22 PCID0
5 DIGITAL G IN	14 DIGITAL SG IN	23 PCID1
6 DIGITAL B IN	15 DIGITAL SB IN	24 DIGITAL GND
7 ANALOG R OUT	16 ANALOG R GND OUT	25 HSYNC OUT
8 ANALOG G OUT	17 ANALOG G GND OUT	26 VSYNC OUT
9 ANALOG B OUT	18 ANALOG B GND OUT	

	ANALOG	DIGITAL
PCID0	OPEN	GND
PCID1	OPEN	OPEN

PCIDs ARE PULLED UP INTERNALLY

## 13 FCC STATEMENT

This equipment has been certified to comply with the limits for a Class A computing device, pursuant to Subpart J of Part 15 of FCC rules. Only peripherals (computer input/output devices, terminals, printers, etc.) certified to comply with the Class A limits may be attached to a computer that complies with Class A limits. When connecting to a peripheral device, a shielded input/output cable is required to ensure compliance with FCC rules. The shielded cable that must be used is supplied with the equipment. Operation with non-certified peripherals or non-shielded cables is likely to result in interference to radio and TV reception.

### INSTRUCTIONS TO USER

This equipment generates and uses radio-frequency energy and, if not installed and used in accordance with the instruction manual, may cause interference to radio and television reception. It has been tested and found to comply with the limits for a Class A computing device in accordance with the specifications in Subpart J of Part 15 of the FCC rules, which are designed to provide reasonable protection against such interference when operated in a commercial environment. However, there is no guarantee that interference will not occur in a particular installation. If this equipment does cause interference to radio or television reception, which can be determined by turning the equipment off and on, the user is encouraged to try to correct the interference by one or more of the following measures :

***Reorient the receiving antenna.***

***Relocate the computer with respect to the receiver.***

***Plug the equipment to a different outlet so that equipment and receiver are on different branch circuits.***

***Fasten cables using mounting screws to ensure adequate EMI control.***

You may require the following booklet from the Federal Communications Commission (FCC) : "How to identify and resolve radio and TV interference problems", available from the U.S. Government Printing Office, Washington, DC 20402, Stock No. 004-000-00345-4.

## 14 ENVIRONMENTAL STATEMENT

This product is manufactured to minimize the stress and pollution of the surroundings. Where possible, recyclable materials are used.

<b><i>ITEM</i></b>	<b><i>RECYCLING / HANDLING</i></b>
PACKAGING	Only recyclable materials are used
MECHANICS	Only recyclable plastics and metal is used. Recycling codes are moulded in the plastic. Metal parts are painted aluminium and steel.
ELECTRONICS	No CFC is used during manufacture. No components that require special handling are used.
LCD MODULE	The liquid does not contain toxic or cancer causing materials. No special ventilation is needed when handling a broken cell. Use gloves and wash your hands afterwards to avoid any irritation to skin. The module is largely made up of glass, so handle broken units carefully to avoid wounds.

## 15 SERVICE INFORMATION

In cases where a problem cannot be solved by the assistance of your dealer, please call the following number to get an **RMA** (Return Authorization Number) :

**+47 69 34 01 55 (Norway)**

To return the defective unit, package well (preferably using the original packaging material), enclose a copy of your sales receipt and a description of the problem you experience, and ship **prepaid** to :

**ASK AS**  
**Customer Service Department**  
**RMA .....**  
**N-1602 FREDRIKSTAD**  
**NORWAY**

Be sure to include your RMA number on the outside of the shipping box, as units without this number will be returned to sender without processing.

## **16 CONNECTION LAYOUT**

The foldout shows how to connect the LCD panel to the different computer sources.